

# KOMATSU®

## WA380-7

Tier 4 Interim Engine

# WA380

### NET HORSEPOWER

191 HP @ 2100 rpm  
142 kW @ 2100 rpm

### OPERATING WEIGHT

39,840–41,115 lb  
18070–18650 kg

### BUCKET CAPACITY

3.8–5.2 yd<sup>3</sup>  
2.9–4.0 m<sup>3</sup>



PHOTOS MAY INCLUDE OPTIONAL EQUIPMENT

WA380

# WALK-AROUND

WA380-7



Photos may include optional equipment

# WA380-7

Tier 4 Interim Engine

**NET HORSEPOWER**  
191 HP @ 2100 rpm  
142 kW @ 2100 rpm

**OPERATING WEIGHT**  
39,840–41,115 lb  
18070–18650 kg

**BUCKET CAPACITY**  
3.8–5.2 yd<sup>3</sup>  
2.9–4.0 m<sup>3</sup>



**A powerful Komatsu SAA6D107E-2 engine** provides a net output of 142 kW **191 HP** with 10% improved fuel consumption. This engine is EPA Tier 4 Interim and EU stage 3B emissions certified.

**Komatsu Variable Geometry Turbocharger (KVGT)** uses a hydraulic actuator to provide optimum air flow under all speed and load conditions.

**Komatsu Diesel Particulate Filter (KDPF)** captures 90% of particulate matter and provides automatic regeneration that does not interfere with daily operation.

#### **Increased cooling capacity**

- Auto-reversing fan is standard
- Wider core coolers
- Standard rear screen

## HIGH PRODUCTION WITH LOW FUEL CONSUMPTION

### **Large capacity torque converter with lock-up:**

- 10% lower fuel consumption
- Faster top speed
- Quick acceleration
- Lock-up in 2<sup>nd</sup>, 3<sup>rd</sup> and 4<sup>th</sup> gear

**Komatsu SmartLoader Logic** helps reduce fuel consumption with no decrease in production.

**An all new cab** provides the operator with improved comfort and visibility.

### **New high resolution monitor panel**

- Enhanced and intuitive on-board diagnostics
- Integrated with KOMTRAX Level 4
- Integrated with Komatsu Tier 4 technology



### **Rearview monitoring system (standard)**

### **New high capacity air suspension seat**

- Seat mounted EPC controls with F-N-R switch
- Seat heater is standard

### **Energy saving guidance**

- Six operator guiding messages
- Enhanced eco-gauge

**Komatsu Auto Idle Shutdown** helps reduce idle time and reduce operating costs.

**Remote boom and bucket positioners** can set kick-outs from inside the cab.

**Variable displacement piston pumps with CLSS** help reduce fuel consumption.

## KOMTRAX®

Komtrax equipped machines can send location, SMR and operation maps to a secure website utilizing wireless technology. Machines also relay error codes, cautions, maintenance items, fuel levels, and much more.

# HIGH PRODUCTIVITY & LOW FUEL CONSUMPTION

WA380-7

## High Performance Komatsu SAA6D107E-2 Engine

The Komatsu SAA6D107E-2 engine is EPA Tier 4 Interim and EU Stage 3B emissions certified and provides exceptional performance while reducing fuel consumption. Based on Komatsu proprietary technologies developed over many years, this new diesel engine reduces exhaust gas particulate matter (PM) by more than 90% and nitrogen oxides (NOx) by more than 45% when compared to Tier 3 levels.

Through the in-house development and production of engines, electronics, and hydraulic components, Komatsu has achieved great advancements in technology, providing high levels of performance and efficiency in virtually all applications. The operator will notice high torque at low speeds, excellent operation and low fuel consumption to provide maximum productivity.



## Komatsu Diesel Particulate Filter (KDPF)

Komatsu has developed a high efficiency diesel particulate filter that captures more than 90% of particulate matter. Both passive and active regeneration are automatically initiated by the engine controller depending on the soot level of the KDPF. A special oxidation catalyst with a fuel injection system is used to oxidize and remove particulate matter while the machine is running so the regeneration process will not interfere with daily operation.

The operator can also initiate regeneration manually or disable regeneration depending on the work environment.

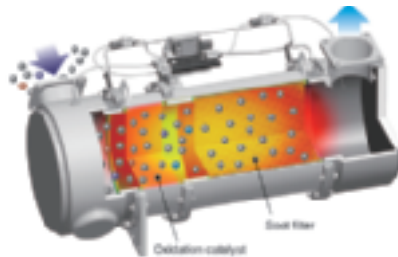

## Closed Crankcase Ventilation (CCV)

Crankcase emissions (blow-by gas) are passed through a CCV filter. The CCV filter traps oil mist which is returned back to the crankcase while the gas, which is almost oil mist free, is fed back to the air intake.

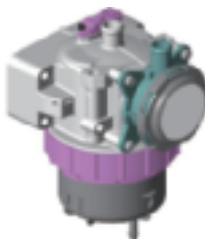

## Heavy Duty High Pressure Common Rail (HPCR) Fuel Injection System

The heavy duty HPCR system is electronically controlled to deliver a precise quantity of pressurized fuel into the combustion chamber using multiple injection events to achieve complete fuel burn and reduce exhaust gas emissions. Fuel injector reliability has been improved by using ultra-hard wear resistant materials.

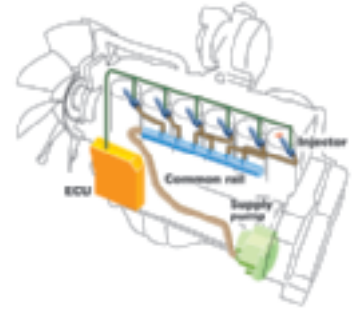

## Komatsu Variable Geometry Turbocharger (KVGT)

Using Komatsu proprietary technology, a newly designed variable geometry turbocharger with a hydraulic actuator is used to manage and deliver optimum air flow to the combustion chamber under all speed and load conditions. The robust hydraulic actuator provides power and precision, resulting in cleaner exhaust gas, quick acceleration and improved fuel economy while maintaining performance.

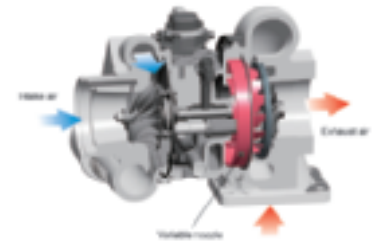

## Redesigned Combustion Chamber

The combustion chamber located at the top of the engine piston has a new shape designed to improve combustion and further reduce NOx, PM, fuel consumption, and noise levels.

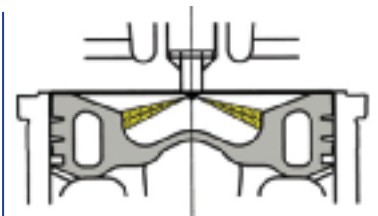

## Cooled Exhaust Gas Recirculation (EGR)

Cooled EGR, a technology that has been well proven in Komatsu Tier 3 engines, reduces NOx emissions to meet Tier 4 levels. The hydraulically actuated EGR system has increased capacity and uses larger and more robust components to ensure reliability for demanding work conditions.

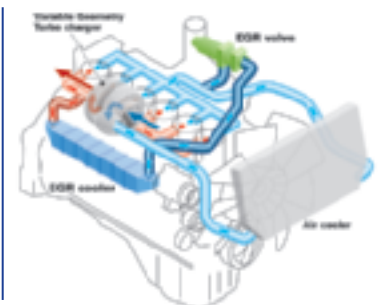

## Advanced Electronic Control System

The engine control system has been upgraded to effectively manage the air flow rate, EGR gas flow rate, fuel injection parameters, and aftertreatment functions. The new control system also provides enhanced diagnostic capabilities.

## Komatsu SmartLoader Logic

The WA380-7 provides Komatsu SmartLoader Logic, a new engine control system. This technology acquires data from various sensors in the vehicle and controls the engine to yield enough torque for each work phase. Engine torque requirements for a wheel loader vary depending on working conditions. For example, the loader requires higher torque for digging in V-shape loading, but less torque when traveling with an empty bucket. This technology limits the engine torque during less demanding work, therefore saving fuel. Komatsu SmartLoader Logic functions automatically and doesn't interfere with operation, saving fuel without decreasing production.

## Large-Capacity Torque Converter

The newly designed power train has a large capacity torque converter for optimum efficiency. The WA380-7 has greater productivity in V-shape loading applications because the increased tractive effort does not require full throttle. The improved hill climbing ability allows the WA380-7 to up-shift gears faster because of improved acceleration. The WA380-7 can achieve higher gear ranges and maintain higher travel speed when working in load-and-carry applications. In most applications, production is increased and fuel consumption is reduced, resulting in improved fuel efficiency.

## Enhanced Lock-Up

The newly designed large-capacity torque converter with lock-up is standard on the WA380-7. The lock-up function activates in 2nd, 3rd and 4th gears to give the loader a maximum travel speed of 40 km/h **24.9 mph**. The large capacity torque converter with enhanced lock-up is effective for both load and carry applications, and V-shape loading which uses lower gears. The enhanced lock-up reduces the clutch engagement shock by controlling engine torque with Komatsu SmartLoader Logic improving operator comfort. The enhanced lock-up combined with Komatsu SmartLoader Logic results in lower fuel consumption and higher travel speeds in load and carry and even some cycle loading applications.

## Komatsu Auto Idle Shutdown

In order to reduce idle time, Komatsu offers Komatsu Auto Idle Shutdown. This function will shut the engine off and apply the parking brake and hydraulic lock after a preset idle time limit. This time limit can be set by the operator or service technician and may range from 3 minutes to 60 minutes.

## Low Fuel Consumption

Komatsu added many new features on the WA380-7 to reduce fuel consumption. These features enable further fuel efficiency by optimally controlling engine power and matching the Komatsu designed and produced high efficiency power train components and hydraulic system.

## 10% Reduction in Fuel consumption

\* Compared with the WA380-6, fuel consumption varies depending on working conditions.

## Dual-Mode Engine Power Select System

This wheel loader offers two selectable operating modes—E and P.

- **E Mode:** This mode provides maximum fuel efficiency for general loading.
- **P Mode:** This mode provides maximum power output for hard digging operations or hill climb applications.



Dual mode engine power selection switch

## Eco-Guidance

The Eco-guidance provides information on the monitor to help save fuel. The monitor displays messages in real-time during operation and on the exit screen when turning the key to shut off the engine. This function can be controlled through the monitor. The operator can view Eco-guide and fuel consumption through the monitor as well as through KOMTRAX.

During operation



User menu for ON/OFF setting

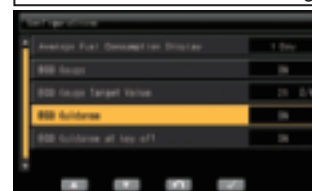

Key OFF

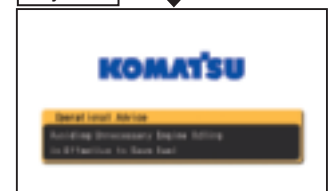

## Variable Displacement Piston Pump & CLSS

The variable displacement piston pump combined with the Closed-center Load Sensing System (CLSS) delivers as much hydraulic flow as the job requires, preventing wasted hydraulic flow. Minimized loss contributes to better fuel economy.

### New Designed Cabin

The new cabin offers better ergonomics, more storage space and more features to improve operator comfort.



WA380-7

#### Operator Seat with EPC (Electronic Pilot Control) Levers

The work equipment control system has an EPC lever console integrated into the higher capacity seat and moves with the seat. The angle of the armrest is fully adjustable for optimum operator comfort. An F-N-R switch is now incorporated in dual and three lever configurations as well as the optional monolever configurations. A heated seat is now standard.



#### Tiltable / Telescopic Steering Wheel

The WA380-7 comes standard with a tiltable and telescopic steering wheel that can be pushed up and out of the way for easy entry and exit of the cab.



#### Low Noise Design

Operator's ear noise level : 72 dB(A)

Dynamic noise level (outside): 108 dB(A)

The large cab is mounted with Komatsu's unique ROPS/FOPS viscous mounts. The low-noise engine, hydraulically driven fan, and hydraulic pumps are mounted with rubber cushions, and the cab sealing is designed to provide a quiet, low-vibration, dustproof, and comfortable operating environment.



#### Increased Cab Storage Area

The WA380-7 cab features a storage box on the left hand side of the cab to allow the operator to store items out of the way. A hot or cold box on the right hand side of the cab allows the operator to keep a beverage or lunch warm or cold, depending on the season.



## Ergonomic Comfort

The dashboard and cab have been redesigned to improve operator comfort. The monitor can be controlled by the multi-switch panel. Also, the front glass of the cab has been lowered to improve visibility.



**Machine Monitor**



**Color Rear View Monitor**



**Multi-switch Panel**



### Rear View Monitoring System (standard)

The operator can view the rear of the machine with a full color monitor that is located on the right side of the cab. This monitor can be always on or only on when the loader goes into reverse. Visual guidelines can also be added for more convenience.



### Seat Belt Caution Indicator

A warning indicator on the monitor appears when the seat belt is not engaged.

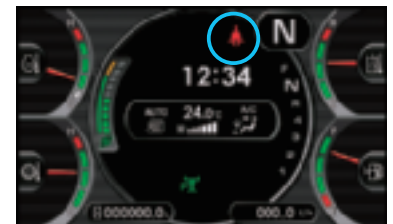

### Engine Shutdown Secondary Switch

The engine stop switch is incorporated to allow shutdown of the machine when accessing the key switch is not possible.

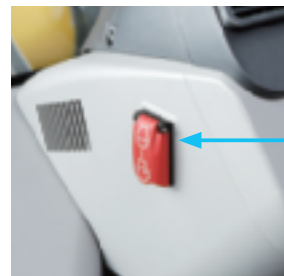

### Auxiliary Input (MP3 Jack) 12 V Outlets

An Aux input to allow use of an MP3 player or other device is now standard as well as two 12 volt outlets. These are all located on the front of the right hand console.

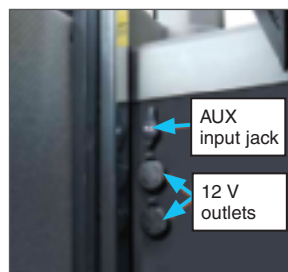



### Easy Entry and Egress

The WA380-7 has an inclined ladder with wide steps and hand holds to ease entry and exit from the cab. The door latch can be reached from ground level to ease opening and closing the door.

### Remote Bucket & Boom Positioner

The operator can set the bucket angle and remote boom positioner from the cab. Both upper and lower boom positions are adjustable in the cab with the push of a button. The bucket positioner can memorize three horizontal settings, allowing the operator to easily change attachments without having to reset the bucket position. In each horizontal setting, the operator can adjust the setting with the switch in the cab. This can help save the operator time when changing attachments.



Remote positioner switch  
Boom / Bucket

### Automatic Kick-down

The WA380-7 has the ability to automatically shift down to F1. This can be activated through the monitor.

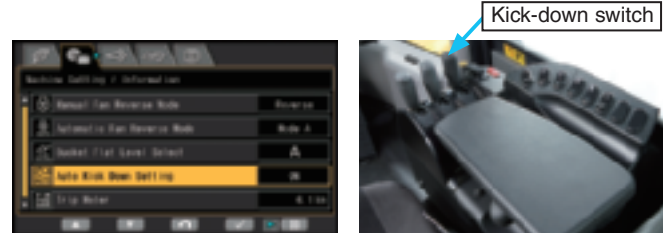

### Electronically Controlled Suspension System (ECSS)

The Electronically Controlled Suspension System (ECSS) or ride control system uses an accumulator which absorbs some of the shock in the boom arm, giving the operator a much smoother ride. This reduces operator fatigue and reduces material spillage during load and carry operations. ECSS is speed sensitive, meaning that the boom won't move during stationary digging. ECSS is standard on the WA380-7.

### New Mono Lever With Integrated 3rd Spool Control (option)

The mono lever option has been redesigned for better ergonomics. When equipped with the optional 3rd spool valve, it allows the operator to control the 3rd spool with your thumb providing greatly improved operator comfort. The 3rd spool valve can be operated in either continuous or proportional flow modes. The mono lever also includes a F-N-R switch.

## INFORMATION & COMMUNICATION TECHNOLOGY

### Large High Resolution Monitor Panel

A new large, user-friendly machine monitor display various machine information and allows for various settings of the machine. The LCD monitor is a 7-inch color TFT-LCD and displays maintenance information, operational records, ECO guidance record, etc.

The switch panel is used to select the various LCD unit screens and the air conditioner control screen. By using the switch panel, you can display various user menus on the screen and perform the settings of the machine.



#### Machine monitor

- |                           |  |
|---------------------------|--|
| ① LCD unit                | ⑧ Engine coolant temperature gauge       |
| ② LED unit                | ⑨ Hydraulic oil temperature gauge        |
| ③ Engine tachometer       | ⑩ Torque converter oil temperature gauge |
| ④ Speedometer             | ⑪ Fuel gauge                             |
| ⑤ ECO gauge               | ⑫ Message pilot lamp                     |
| ⑥ Air conditioner display | ⑬ Pilot lamps                            |
| ⑦ Shift indicator         |  |

#### Switch panel

- ① Air conditioner switches / Numeral key pad      ② Function switches

### Large LCD Monitor

The LCD monitor displays various information of the machine such as ECO Guidance, operation records, and maintenance information. Since the LCD unit has a wide full color display area, it displays more information and is easy to read. For example, the "Operation Records" menu displays various records of the actual working hours, average fuel consumption, idling hours, and E mode operation ratio, as well as other features. These records are displayed in the form of daily data and time period data. Data can be displayed in 25 languages to support operators around the world. The controls for the automatic air conditioner are integrated into the LCD monitor panel to allow the operator to easily and precisely set the cab atmosphere.

The monitor clearly displays abnormality codes to alert the operator. These codes are stored for trouble shooting. The monitor also provides for advanced monitoring of system parameters through the Service Mode to aid in troubleshooting and reduce downtime.



Main Display



Operational Records Display



Service Mode Display



Photos may include optional equipment

### Full Side-Opening Gull-Wing Engine Doors

The large gull-wing type engine doors are operated with low effort assisted by gas springs. The doors open in two steps. The first position is for daily maintenance and the second position is for periodic maintenance. Large steps are provided on each side of the frame to help access.



Photos may include optional equipment

### Auto Reversing Fan

The engine cooling fan is driven hydraulically. It can be set to reverse automatically during operation. Fan reverse mode and timing can be controlled through the monitor.



### Maintenance Function

The monitor informs the operator when the replacement interval for oil and filters will be reached.



### Swing-out Type Cooling Unit

The large capacity cooling unit swings open for cleaning. It features wider spacing of cooling fins to reduce clogging. A rear screen is also standard to reduce the amount of debris that can enter the engine compartment.



Photos may include optional equipment

### Battery Disconnect

The battery disconnect switch is located in front of the right side battery box. This can be used to disconnect power when performing service work on the machine.



## Engine Compartment

The WA380-7 engine compartment was laid out for easy serviceability. Great attention was paid to the location of the maintenance items, such as the filters, dipsticks and oil fill locations. The same goes for the KDPF and CCV filter, as even the top of the hood was redesigned to ease removal of the KDPF for cleaning or replacement.



## KDPF Regeneration

Soot trapped by and accumulated in the KDPF is removed by burning it periodically and automatically.



KDPF regeneration indicator

## Manual Stationary Regeneration

Under most conditions, active regeneration will occur automatically with no effect on machine operation. In case the operator needs to disable active regeneration or initiate a manual stationary regeneration, this can be easily accomplished through the monitor panel.

A soot level indicator is displayed to show how much soot is trapped in the KDPF.

Soot level indicator

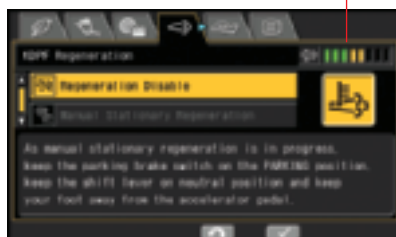

## Rear Full Fenders (Option)

The WA380-7 has a new rear fender option. The plastic rear fenders now open outward, keeping the force to open the engine doors low, even when there is mud or snow on the fenders. The fenders swing far out of the way to give the technician easy access to the engine compartment. Mudflaps are also included on the rear fenders.



Photos may include optional equipment

## LED Taillights

LED tail lamps / brake lamps and reverse lamps provide long bulb life and use less power than the ones on the WA380-6.



## Cab Air Intake Filter

The cab air intake filter is located on the front of the cab, on the left hand side of the machine behind a lockable door, for easy access and security.





## Komatsu CARE – Complimentary Scheduled Maintenance

- PM services for the earlier of 3 years / 2000 hours
- Performed by factory certified technicians
- Komatsu Genuine parts and fluids
- Significantly lowers your cost of ownership while maintaining high uptime and reliability
- Increases resale value and provides detailed maintenance records
- Extended PM services can be purchased beyond the complimentary period to provide additional peace of mind and maximize uptime



## Komatsu CARE – Extended Coverage

- Extended Coverage can provide peace of mind by protecting customers from unplanned expenses that effect cash flow
- Purchasing extended coverage locks-in the cost of covered parts and labor for the coverage period and helps turn these into fixed costs



## Komatsu Parts Support

- 24/7/365 to fulfill your parts needs
- 9 parts Distribution Centers strategically located across the U.S. and Canada
- Distributor network of more than 300 locations across U.S. and Canada to serve you
- Online part ordering through Komatsu eParts
- Remanufactured components with same-as-new warranties at a significant cost reduction



## Komatsu Oil and Wear Analysis (KOWA)

- KOWA detects fuel dilution, coolant leaks, and measures wear metals
- Proactively maintain your equipment
- Maximize availability and performance
- Can identify potential problems before they lead to major repairs
- Reduce life cycle cost by extending component life

# KOMTRAX EQUIPMENT MONITORING

GET THE WHOLE STORY WITH **KOMTRAX**<sup>®</sup>

## ✓ WHAT

- KOMTRAX is Komatsu's remote equipment monitoring and management system
- KOMTRAX **continuously monitors and records** machine health and operational data
- Information such as fuel consumption, utilization, and a detailed history **aids in making repair or replacement decisions**

## ✓ WHEN

- Know when your machines are **running or idling** and make decisions that will improve your fleet utilization
- Detailed movement records ensure you know when and where your equipment is moved
- Up to date records allow you to **know when maintenance was done** and help you plan for future maintenance needs

## ✓ WHERE

- KOMTRAX data **can be accessed virtually anywhere** through your computer, the web or your smart phone
- Automatic alerts keep fleet managers up to date on the latest machine notifications

## ✓ WHY

- Knowledge is power - **make informed decisions** to manage your fleet better
- Knowing your idle time and fuel consumption will help maximize your machine efficiency
- **Take control of your equipment** - any time, anywhere

## ✓ WHO

- KOMTRAX is **standard** equipment on all Komatsu construction products

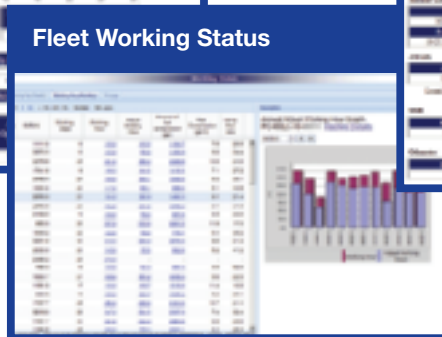
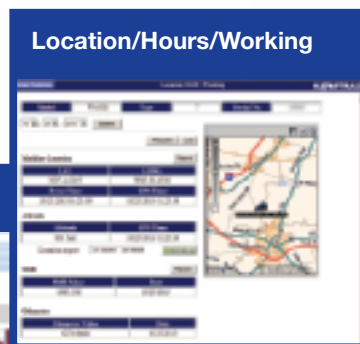

**KOMTRAX**<sup>®</sup>

For construction and compact equipment.

**KOMTRAX Plus**<sup>™</sup>

For production and mining class machines.



## ENGINE

Model..... Komatsu SAA6D107E-2\*  
 Type..... Water-cooled, 4-cycle  
 Aspiration..... Turbo-charged, after-cooled  
 Number of cylinders..... 6  
 Bore..... 107 mm **4.21"**  
 Stroke..... 124 mm **4.88"**  
 Piston displacement..... 6.69 ltr **408 in³**  
 Governor..... All-speed, electronic  
 Horsepower:  
   SAE J1995.....Gross 143 kW **192 HP**  
   ISO 9249 / SAE J1349..... Net 142 kW **191 HP**  
   Rated rpm..... 2100 rpm  
 Fan drive method for radiator cooling.....Hydraulic  
 Fuel system.....Direct injection  
 Lubrication system:  
   Method.....Gear pump, force-lubrication  
   Filter.....Full-flow type  
 Air cleaner..... Dry type with double elements and dust evacuator, plus dust indicator

\*EPA Tier 4 Interim and EU stage 3B emissions certified



## TRANSMISSION

Torque converter..... 3-elements, 1-stage, 2-phase  
 Transmission.....Automatic, full-powershift, counter-shaft type

Travel speed	Forward*	Reverse*
<b>1st</b>	6.6 km/h <b>4.1 mph</b>	7.1 km/h <b>4.4 mph</b>
<b>2nd</b>	11.7 km/h <b>7.3 mph</b> (12.4 km/h <b>7.7 mph</b> )	12.4 km/h <b>7.7 mph</b> (13.3 km/h <b>8.3 mph</b> )
<b>3rd</b>	20.9 km/h <b>13.0 mph</b> (22.5 km/h <b>14.0 mph</b> )	22.3 km/h <b>13.9 mph</b> (24.1 km/h <b>15.0 mph</b> )
<b>4th</b>	36.1 km/h <b>22.4 mph</b> (40.0 km/h <b>24.9 mph</b> )	38.6 km/h <b>24.0 mph</b> (40.0 km/h <b>24.9 mph</b> )

\*P-mode    Measured with 23.5-25 tires    ( ): Lock-up clutch ON



## AXLES AND FINAL DRIVES

Drive system..... Four-wheel drive  
 Front..... Fixed, semi-floating  
 Rear..... Center-pin support, semi-floating, 26° total oscillation  
 Reduction gear.....Spiral bevel gear  
 Differential gear..... Conventional type  
 Final reduction gear..... Planetary gear, single reduction



## BRAKES

Service brakes..... Hydraulically actuated, wet disc brakes actuate on four wheels  
 Parking brake..... Wet disc brake  
 Emergency brake..... Parking brake is commonly used



## STEERING SYSTEM

Type..... Articulated type, fully-hydraulic power steering  
 Steering angle..... 35° (40° to max end stop)  
 Minimum turning radius at the center of outside tire..... 6320 mm **20' 9"**



## HYDRAULIC SYSTEM

Steering system:  
 Hydraulic pump..... Piston type  
 Capacity..... 137 ltr/min **36.2 U.S. gal/min** at rated rpm  
 Relief valve setting..... 24.5 MPa 250 kgf/cm² **3,555 psi**  
 Hydraulic cylinders:  
   Type..... Double-acting, piston type  
   Number of cylinders..... 2  
   Bore x stroke..... 75 mm x 442 mm **3.0" x 17.4"**

Loader control:  
 Hydraulic pump..... Piston pump  
 Capacity..... 204.9 ltr/min **54.13 U.S gal/min**  
 Relief valve setting..... 31.4 MPa 320 kgf/cm² **4,550 psi**  
 Hydraulic cylinders:  
   Type..... Double-acting, piston type  
   Number of cylinders—bore x stroke:  
     Boom cylinder..... 2- 130 mm x 713 mm **5.1" x 28.1"**  
     Bucket cylinder..... 1- 150 mm x 535 mm **5.9" x 21.1"**  
 Control valve..... 2-spool type  
 Control positions:  
   Boom..... Raise, hold, lower, and float  
   Bucket..... Tilt-back, hold, and dump  
 Hydraulic cycle time (rated load in bucket)  
   Raise..... 5.9 s  
   Dump..... 1.8 s  
   Lower (Empty)..... 3.3 s



## SERVICE REFILL CAPACITIES

Cooling system..... 54.4 ltr **14.4 U.S. gal**  
 Fuel tank..... 300 ltr **79.3 U.S. gal**  
 Engine..... 23 ltr **6.1 U.S. gal**  
 Hydraulic system..... 142 ltr **37.5 U.S. gal**  
 Axle (each front and rear)..... 40 ltr **10.6 U.S. gal**  
 Torque converter and transmission..... 54 ltr **14.3 U.S. gal**



## BUCKET SELECTION GUIDE

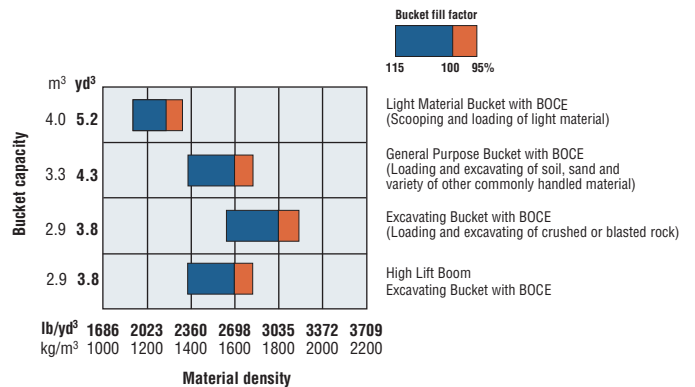



## DIMENSIONS

Measured with 23.5-R25 (L3) tires, ROPS/FOPS cab

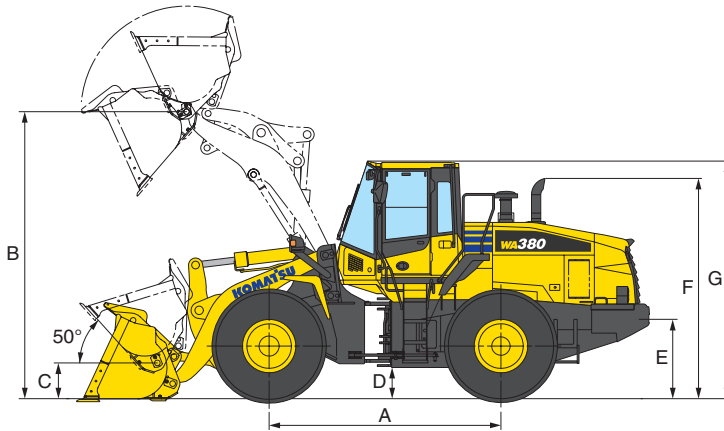

Tread		2160 mm	<b>7'1"</b>
Width over tires		2780 mm	<b>9'1"</b>
A Wheelbase		3300 mm	<b>10'10"</b>
B Hinge pin height,	Standard Boom	4095 mm	<b>13'5"</b>
max. height	High Lift Boom	4625 mm	<b>15'2"</b>
C Hinge pin height,	Standard Boom	520 mm	<b>1'8"</b>
carry position	High Lift Boom	680 mm	<b>2'3"</b>
D Ground clearance		455 mm	<b>1'6"</b>
E Hitch height		1150 mm	<b>3'9"</b>
F Overall height, top of the stack		3145 mm	<b>10'3"</b>
G Overall height, ROPS cab		3390 mm	<b>11'2"</b>

	General Purpose Bucket	Excavating Bucket	Light Material Bucket	High Lift Boom Excavating Bucket
	Bolt-on Cutting Edge	Bolt-on Cutting Edge	Bolt-on Cutting Edge	Bolt-on Cutting Edge
Bucket capacity: heaped	3.3 m <sup>3</sup> <b>4.3 yd<sup>3</sup></b>	2.9 m <sup>3</sup> <b>3.8 yd<sup>3</sup></b>	4.0 m <sup>3</sup> <b>5.2 yd<sup>3</sup></b>	2.9 m <sup>3</sup> <b>3.8 yd<sup>3</sup></b>
struck	2.9 m <sup>3</sup> <b>3.8 yd<sup>3</sup></b>	2.4 m <sup>3</sup> <b>3.1 yd<sup>3</sup></b>	3.4 m <sup>3</sup> <b>4.4 yd<sup>3</sup></b>	2.4 m <sup>3</sup> <b>3.1 yd<sup>3</sup></b>
Bucket width	2905 mm <b>9'6"</b>	2905 mm <b>9'6"</b>	2905 mm <b>9'6"</b>	2905 mm <b>9'6"</b>
Bucket weight	1605 kg <b>3,570 lb</b>	1715 kg <b>3,790 lb</b>	1835 kg <b>4,045 lb</b>	1715 kg <b>3,790 lb</b>
Dumping clearance, max. height and 45° dump angle*	2950 mm <b>9'8"</b>	3045 mm <b>10'0"</b>	2855 mm <b>9'4"</b>	3575 mm <b>11'9"</b>
Reach at max. height and 45° dump angle*	1150 mm <b>3'9"</b>	1055 mm <b>3'6"</b>	1240 mm <b>4'1"</b>	1185 mm <b>3'11"</b>
Reach at 2130 mm (7') clearance and 45° dump angle*	1735 mm <b>5'8"</b>	1630 mm <b>5'6"</b>	1780 mm <b>5'10"</b>	2205 mm <b>7'3"</b>
Reach with arm horizontal and bucket level*	2590 mm <b>8'6"</b>	2450 mm <b>8'0"</b>	2715 mm <b>8'11"</b>	2940 mm <b>9'8"</b>
Operating height (fully raised)	5600 mm <b>18'5"</b>	5450 mm <b>17'11"</b>	5720 mm <b>18'9"</b>	5985 mm <b>19'7"</b>
Overall length	8280 mm <b>26'8"</b>	8140 mm <b>26'3"</b>	8255 mm <b>27'1"</b>	8780 mm <b>28'10"</b>
Loader clearance circle (bucket at carry, outside corner of bucket)	14440 mm <b>47'5"</b>	14370 mm <b>47'2"</b>	14500 mm <b>47'7"</b>	14850 mm <b>48'9"</b>
Digging depth: 0°	60 mm <b>2.4"</b>	60 mm <b>2.4"</b>	60 mm <b>2.4"</b>	110 mm <b>4.3"</b>
10°	290 mm <b>11.4"</b>	265 mm <b>10.4"</b>	315 mm <b>1'0"</b>	320 mm <b>12.6"</b>
Static tipping load: straight	15565 kg <b>34,140 lb</b>	15450 kg <b>33,885 lb</b>	15330 kg <b>33,620 lb</b>	14660 kg <b>32,320 lb</b>
40° full turn	13295 kg <b>29,145 lb</b>	13180 kg <b>28,900 lb</b>	13055 kg <b>28,625 lb</b>	10500 kg <b>23,150 lb</b>
Breakout force	158 kN 16100 kgf <b>35,495 lb</b>	175 kN 17850 kgf <b>39,680 lb</b>	144 kN 14700 kgf <b>32,405 lb</b>	183 kN 18700 kgf <b>41,220 lb</b>
Operating weight	18155 kg <b>39,840 lb</b>	18265 kg <b>40,170 lb</b>	18385 kg <b>40,950 lb</b>	18650 kg <b>41,115 lb</b>

\*At the end of tooth or B.O.C.

All dimensions, weights, and performance values based on SAE J732c and J742b standards.

Static tipping load and operating weight shown include lubricant, coolant, full fuel tank, ROPS cab, and operator.

Machine stability and operating weight affected by counterweight, tire size, and other attachments.

Apply the following weight changes to operating weight and static tipping load.



## WEIGHT CHANGES

Tires or attachments	Operating weight		Tipping load straight		Tipping load full turn	
	kg	lb	kg	lb	kg	lb
Remove additional counterweight	-245	-540	-855	-1885	-715	-1575



## STANDARD EQUIPMENT

- 2-spool valve for boom and bucket control
- Alternator, 60 A
- Auto shift transmission with mode select system
- Automatic hydraulic-driven fan with automatic reverse rotation
- Back-up alarm
- Back-up lamp, LED
- Battery disconnect
- Batteries, 150 Ah/12 V (2)
- Boom Kick-out, in-cab adjustable
- Bucket Positioner, in-cab adjustable, 3 positions
- Color rear view camera and monitor
- Counterweight, standard and additional
- Electronically Controlled Suspension System (ECSS)
- Engine, Komatsu SAA6107E-2 diesel
- Engine shut-off system, electric
- EPC fingertip controls with F-N-R switch, two levers
- Equipment Management Monitoring System (EMMS)
  - Lights (central warning, brake oil pressure, engine oil pressure, parking brake, cooling fan reverse, KDPF restriction, seat belt caution, Komtrax message)
- Gauges (Engine water temperature, ECO, Fuel level, Hydraulic oil temperature, speedometer/tachometer)
  - Front Fenders
  - Fuel pre-filter with water separator
  - Horn, electric
  - Komatsu SmartLoader Logic
  - Komatsu Auto Idle Shutdown
  - KOMTRAX® Level 4
  - Lift cylinders and bucket cylinder
  - Lights
    - Back-up light, LED
    - Stop and tail light, LED
    - Turn signal, 2 front and 2 rear with hazard switch
    - Working lights, halogen, 2 front cab mount
    - Working lights, halogen, 2 front fender mount
    - Working lights, halogen, 2 rear grill mount
  - Loader linkage with standard lift arm
  - Lock-up torque converter
  - Parking brake, electric
  - Provision for JRB quick coupler
  - Radiator, wider core
  - Radiator mask, lattice type
  - Rear view mirrors, outside (2) inside (2)
- ROPS/FOPS Cab Level 2
  - 2 x DC12V electrical outlets
  - Ashtray
  - Auto air conditioner
  - Cigarette lighter, 24V
  - Color LCD/TFT multi-monitor, high resolution
  - Cup holder
  - Floor mat
  - Operator seat, reclining, air suspension type, heated
  - Radio, AM/FM with AUX input jack
  - Rear defroster, electric
  - Rear window washer and wiper
  - Seat, heated, air suspension
  - Seatbelt, 2-point retractable, 76mm 3" width
  - Space for Lunch box
  - Steering wheel, tilt and telescopic
  - Sun visor, front window
  - Windshield washer and wiper, front with intermittent
  - Windshield washer and wiper, rear
- Service brakes, wet disc type
- Starting motor, 5.5 kW
- Rims for 23.5-25 tires
- Transmission, 4 forward and 4 reverse
- Vandalism protection kit, padlocks for battery box (2)



## OPTIONAL EQUIPMENT

- 3-spool valve with lever and piping
- Cutting edge (bolt-on type)
- Auxiliary steering (SAE)
- Engine pre-cleaner with extension
- High-lift boom
- Limited slip differential (F&R)
- Monolever loader control with transmission F-N-R switch
- Rear full fenders
- Various tire options, radial and bias
- Various bucket options



## ALLIED EQUIPMENT

- JRB bucket, General Purpose 4.0 yd³ for use with coupler
- JRB bucket, Multi-purpose 3.25 yd³ for use with coupler
- JRB fork, Construction 106" carriage, 60" tines for use with coupler
- JRB fork, Utility Pallet 96" carriage, 72" tines for use with coupler
- JRB boom-Extendable 3 section, 13' 7" extension for use with coupler
- JRB hydraulic quick coupler
- Loadrite weighing system
- Loadrite weighing system, printer, LP950
- Loadrite weighing system, with Material Management System

WA380-7

# KOMATSU®

